



# iota international



The Leading Manufacturer & Exporter of Electronic Products & Accessories Since 1996

B-47, East Uttam Nagar, New Delhi-110059 (INDIA) Contact no. 011-28566590 9810021697 sales@iota.in

Electronic Siren, Emergency Panic Switches, Panic Alarm, LED Light, SMPS & Accessories

## SPECIFICATION OF ELECTRONIC SIREN SPR2WDN

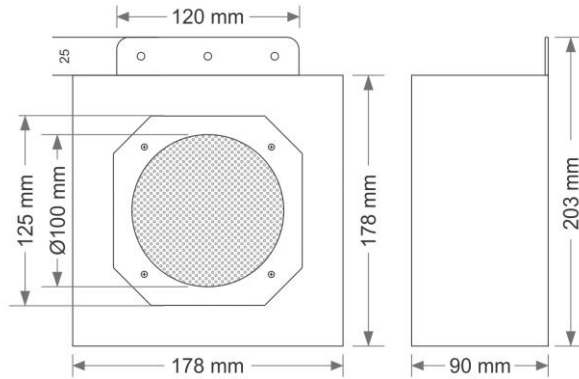

All dimension are in mm tolerance  $\pm 0.2$ mm

- Product : Electronic Siren
- Product Code : SPR2WDN
- Power : 20 Watt
- Impedance : 8 Ohm
- Material of Housing : Wooden Enclosure with Plastic Grill
- Color : Black
- Dimension : 178mm X 178mm X 90mm
- Weight : 1.5 kg (Approx. with packing)
- Mounting Bracket : Top side Metal Clamp
- Warranty : One year against any manufacturing defect

### Important Notes:

**Tones** : We can provide all type international and Indian standard Siren/Alarm tones along with customized tones.

**Voltage** : This product is also available in 6V / 9V / 12V/ 18V / 24V DC & 220V AC

We also welcome Customer's Design & Specifications, For more Product Log on [www.iotasiren.com](http://www.iotasiren.com)

